



Solaranlagen  
Centrales solaires  
Impianti solari



Wasserversorgung  
Approvisionnement en eau  
Approvvigionamento idrico



Kühlanlagen  
Systèmes de refroidissement  
Sistemi di raffreddamento



Heizanlagen  
Systèmes de chauffage  
Sistemi di riscaldamento



## Gewindefittings aus INOX

### Raccords acier inoxydable

### Raccordi acciaio inossidabile















# 316/V4A





















zertifiziert\*  
certifié\*  
certificato\*

\*Details Seite 2 und 3 / \*Détails page 2 et 3 / \*Dettagli pagina 2 e 3

Bruttopreise gültig ab  
Prix brut valable à partir du  
Prezzi lordi valido da  
1.10.2020

	Allgemeine Informationen <i>Informations générales</i> <i>Informazioni generali</i>	4
	Einsatzbereiche INOX-Gewindefittings <i>Champs d'application des raccords en acier inoxydable</i> <i>Campi di utilizzo dei raccordi filettati in acciaio inossidabile</i>	6 7 8
	Anwendungen <i>Applications</i> <i>Applicazioni</i>	9
	Montageanleitung <i>Instructions de montage</i> <i>Istruzioni di montaggio</i>	10
	Edelstahlrohr dickwandig zum Gewinde schneiden - 1.4404 / 316L / V4A <i>Tube en acier inox à parois épaisses pour enfiler - 1.4404 / 316L / V4A</i> <i>Manicotto breve filettato acciaio inossidabile 316</i>	11
	* Muffe Edelstahl 316 <i>Manchon acier inoxydable 316</i> <i>Manicotto acciaio inossidabile 316</i>	11
	* Doppelnippel Edelstahl 316 <i>Mamelon double acier inoxydable 316</i> <i>Bocciolo doppio acciaio inossidabile 316</i>	12
	* Doppelnippel reduziert AG/AG Edelstahl 316 <i>Mamelon réduit m/m acier inoxydable 316</i> <i>Bocciolo ridotto m/m acciaio inossidabile 316</i>	12
	* Reduziermuffe Edelstahl 316 <i>Manchon réduit acier inoxydable 316</i> <i>Manicotto ridotto acciaio inossidabile 316</i>	13
	Reduzierstück IG/AG Edelstahl 316 <i>Mamelon réduit f/m acier inoxydable 316</i> <i>Bocciolo ridotto f/m acciaio inossidabile 316</i>	13
	* Reduziernippel AG/IG Edelstahl 316 <i>Mamelon réduit m/f acier inoxydable 316</i> <i>Bocciolo ridotto m/f acciaio inossidabile 316</i>	14
	* Gewindemuffe Edelstahl 316 <i>Manchon fileté acier inoxydable 316</i> <i>Manicotto filettato acciaio inossidabile 316</i>	14
	Gewindemuffe kurz Edelstahl 316 <i>Manchon court fileté acier inoxydable 316</i> <i>Manicotto breve filettato acciaio inossidabile 316</i>	15
	Gewindenippel Edelstahl 316 <i>Mamelon fileté acier inoxydable 316</i> <i>Niplo filettato acciaio inossidabile 316</i>	15
	* Langnippel Edelstahl 316 <i>Mamelon double longue acier inoxydable 316</i> <i>Bocciolo doppio lunghi acciaio inossidabile 316</i>	16 - 19
	* Schweissnippel Edelstahl 316 <i>Mamelon de soudage acier inoxydable 316</i> <i>Bocciolo saldatura acciaio inossidabile 316</i>	20
	* Winkel 90° IG/IG Edelstahl 316 <i>Coude 90° f/f acier inoxydable 316</i> <i>Gomito 90° f/f acciaio inossidabile 316</i>	21
	* Winkel 90° IG/AG Edelstahl 316 <i>Coude 90° f/m acier inoxydable 316</i> <i>Gomito 90° f/m acciaio inossidabile 316</i>	21
	* Winkel 90° reduziert IG/IG Edelstahl 316 <i>Coude 90° réduit f/f acier inoxydable 316</i> <i>Gomito 90° ridotto f/f acciaio inossidabile 316</i>	21

	Winkel 45° IG/IG Edelstahl 316 <i>Coude 45° f/f acier inoxydable 316</i> <i>Gomito 45° f/f acciaio inossidabile 316</i>	22
	* Winkel 45° IG/AG Edelstahl 316 <i>Coude 45° f/m acier inoxydable 316</i> <i>Gomito 45° f/m acciaio inossidabile 316</i>	22
	* T-Stück Edelstahl 316 <i>Té acier inoxydable 316</i> <i>Tee acciaio inossidabile 316</i>	22
	* T-Stück reduziert Edelstahl 316 <i>Té réduit acier inoxydable 316</i> <i>Tee ridotto acciaio inossidabile 316</i>	22
	* Kreuz Edelstahl 316 <i>Croix acier inoxydable 316</i> <i>Crocce acciaio inossidabile 316</i>	23
	* Rohrverschraubung AG/IG konisch dichtend Edelstahl 316 <i>Union conique m/f acier inoxydable 316</i> <i>Bocchettone conico m/f inossidabile 316</i>	23
	Rohrverschraubung AG/IG flach dichtend Edelstahl 316 <i>Union conique á joint plat m/f acier inoxydable 316</i> <i>Bocchettone conico m/f acciaio inossidabile 316</i>	23
	* Rohrverschraubung AG/AG konisch dichtend Edelstahl 316 <i>Union conique m/m acier inoxydable 316</i> <i>Bocchettone conico m/m acciaio inossidabile 316</i>	23
	* Rohrverschraubung IG/IG konisch dichtend Edelstahl 316 <i>Union conique f/f acier inoxydable 316</i> <i>Bocchettone conico f/f acciaio inossidabile 316</i>	24
	Rohrverschraubung IG/IG flach dichtend Edelstahl 316 <i>Union conique á joint plat f/f acier inoxydable 316</i> <i>Bocchettone conico f/f acciaio inossidabile 316</i>	24
	* Anschweisverschraubung I/I Edelstahl 316 <i>Union soudage f/f acier inoxydable 316</i> <i>Bocchettone f/f saldatura inossidabile 316</i>	24
	* Anschweisverschraubung A/A Edelstahl 316 <i>Union soudage m/m acier inoxydable 316</i> <i>Bocchettone saldatura m/m acciaio inossidabile 316</i>	25
	* Gegenmutter Edelstahl 316 <i>Contre-écrou acier inoxydable 316</i> <i>controdado acciaio inossidabile 316</i>	25
	* Stopfen Hexagon Edelstahl 316 <i>Bouchon Hexagon acier inoxydable 316</i> <i>Tappo Hexagon acciaio inossidabile 316</i>	26
	* Stopfen 4-kant ohne Rand Edelstahl 316 <i>Bouchon carré acier inoxydable 316</i> <i>Tappo quadrato acciaio inossidabile 316</i>	26
	* Kappe Edelstahl 316 <i>Bonnet double acier inoxydable 316</i> <i>Tappo doppio acciaio inossidabile 316</i>	26
	* Kappe Hexagon Edelstahl 316 <i>Bonnet Hexagon acier inoxydable 316</i> <i>Tappo Hexagon acciaio inossidabile 316</i>	27
	* Schlauchnippel Edelstahl 316 <i>Raccord de tuyau acier inoxydable 316</i> <i>Capezzolo tubo acciaio inossidabile 316</i>	27
	* Gewindeflansch PN 16, gebohrt, DIN 2566, Edelstahl 316 <i>Bride filetée PN 16, percée, DIN 2566, inox 316</i> <i>Flangia filettata PN 16, forata, DIN 2566, inox 316</i>	27

## Allgemeine Informationen

Das umfangreiche Sortiment mit nahezu 500 verschiedenen Artikeln deckt durchgängig die Dimensionen von 1/8" – 4" ab. Die Einsatzmöglichkeiten reichen von der Gebäudeversorgungstechnik wie beispielsweise Wasserversorgung, Heizungs-, Solar- oder Kühlanlagen bis zu Anwendungen im Bereich der Pneumatik etc.

### Qualität und Zulassungen

Unsere jahrzehntelange Erfahrung in der Verbindungstechnik und die konsequente Anwendung der Vorgaben der DIN EN ISO 9001 garantieren einen gleichbleibend hohen Qualitätsstandard. Weitere bestehende Zulassungen nennen wir Ihnen gerne auf Anfrage.

### Werkstoffe

Die Inox Fittings werden aus lösungsgelühtem molybdänhaltigem Edelstahl V4A (AISI 316L) nach DIN EN 10088 hergestellt.

Die Inox Rohre sind erhältlich aus dem Werkstoff V4A und V2A.

### Gewinde

Sämtliche an unseren Fittings vorhandenen Rohrgewinde entsprechen DIN EN 10226-1 (ISO 7-1) und sind demgemäß «im Gewinde dichtend» (Gewindepaarung konische Aussengewinde/zylindrische Innengewinde R/Rp).

Die Gewinde unserer Verschraubungen entsprechen DIN EN ISO 228-1 (Gewindepaarung zylindrische Aussen- und Innengewinde G/G).

### Verarbeitung & Montage

Beim Einsatz von Inox-Fittings sind zunächst die in Kapitel 2 genannten Anwendungsparameter zu beachten.

Inox Fittings können mit allen Edelstahlrohren nach DIN EN 10312 und SVGW Prüfgrundlage ZW 132 verarbeitet werden.

Der Einsatz verschiedener Werkstoffe in einem Trinkwassersystem entspricht den Regeln der Technik. Edelstahl, Kupfer, innenverzinntes Kupfer und Kupferle-

## Informations générales

*L'assortiment complet, qui comprend près de 500 articles différents, couvre toutes les dimensions allant de 1/8" à 4". Les utilisations possibles vont de la technique d'approvisionnement des bâtiments (p. ex. l'alimentation en eau, les systèmes de chauffage, les centrales solaires ou les systèmes de refroidissement) aux applications du secteur pneumatique etc.*

### Qualité et autorisations

*Notre expérience de plusieurs décennies en technique d'assemblage et l'application logique des directives de la norme DIN EN ISO 9001 garantissent un standard de qualité continuellement élevé. Nous pouvons fournir d'autres autorisations actuelles sur demande.*

### Matériaux

*Les raccords acier inoxydable sont fabriqués en acier inoxydable contenant du molybdène à l'état de recuit de mise en solution V4A (AISI 316L) conformément à la norme DIN EN 10088.*

*Les tubes en acier inoxydable sont disponibles dans le matériel V4A et V2A.*

### Filets

*Tous les filets de tubes présents sur nos raccords de serrage correspondent à la norme DIN EN 10226-1 (ISO 7-1) et sont par conséquent «étanches dans le filet» (paire de filets mâle conique/femelle cylindrique R/Rp). Les filets de nos raccords correspondent à la norme DIN EN ISO 228-1 (paire de filets mâle-femelle cylindriques G/G).*

### Utilisation et montage

*Veillez d'abord respecter les paramètres cités au chapitre 2 pour l'utilisation des raccords en acier inoxydable.*

*Les raccords en acier inoxydable peuvent être utilisés avec tous les tubes en acier inoxydable correspondant à la norme DIN EN 10312 et à la base d'essai ZW 132 du SVGW.*

*L'utilisation de différents matériaux dans un système d'eau potable correspond aux règles de la technique. Par conséquent, il*

## Informazioni generali

*L'ampio assortimento comprendente quasi 500 diversi articoli copre tutte le dimensioni comprese tra 1/8" e 4". Le possibilità di impiego di questi prodotti spaziano dall'impiantistica degli edifici (ad es. l'approvvigionamento idrico, i sistemi di riscaldamento e raffreddamento e gli impianti solari) alle applicazioni in ambito pneumatico e altro.*

### Qualità e certificazioni

*La nostra decennale esperienza nella tecnica di collegamento e l'applicazione coerente dei requisiti della norma DIN EN ISO 9001 garantiscono uno standard di qualità costantemente elevato. Su richiesta, saremo lieti di indicarvi altre certificazioni conseguite.*

### Materiali

*I raccordi in acciaio inossidabile sono prodotti con un acciaio inox al molibdeno ricotto in soluzione V4A (AISI 316L) secondo la norma DIN EN 10088.*

*I tubi in acciaio inox sono disponibili in materiale V4A et V2A.*

### Filettature

*Tutte le filettature presenti sui nostri raccordi a pressione sono conformi alla norma DIN EN 10226-1 (ISO 7-1) e sono di conseguenza "a tenuta sul filetto" (accoppiamento filettatura esterna conica/filettatura interna cilindrica R/Rp). Le filettature dei nostri raccordi a vite sono conformi alla norma DIN EN ISO 228-1 (accoppiamento filettature esterna e interna cilindriche G/G).*

### Lavorazione e montaggio

*In caso di impiego dei raccordi in acciaio inossidabile, si dovranno rispettare innanzi tutto i parametri di applicazione indicati nel capitolo 2.*

*I raccordi in acciaio inossidabile possono essere lavorati con tutti i tubi in acciaio inox conformemente alla norma DIN EN 10312 e al criterio di prova SVGW ZW 132.*

*L'uso di materiali diversi in un sistema di acqua potabile è conforme alle regole della tecnica. È quindi possibile combinare senza problemi acciaio inossidabile, rame, rame*

gierungen können demnach problemlos kombiniert werden.

Bei der Projektierung und Erstellung von Rohrleitungen sind generell die allgemein anerkannten Regeln der Technik für das jeweilige Gewerk (für Trinkwasserinstallationen z. B. DIN EN 806 und DIN 1988) zu beachten.

### Anwendungsgebiete

- Trinkwasserverteilsysteme für kaltes und erwärmtes Trinkwasser
- Heizungs- und Kühlsysteme einschliesslich Fussboden-, Wand- und Deckenheizsysteme
- Verteilung gasförmiger und flüssiger Brennstoffe
- Thermische Solaranlagen
- Löschwasserleitungen und Sprinkleranlagen
- Druckluftanlagen
- Anlagen zur Verteilung technischer Gase
- Regen- und Betriebswässer
- Gewerblich-industrielle Anwendungen (Hydraulik, Pneumatik)
- Abwasser (z. B. Druckleitungen für Abwasserhebeanlagen)

### Korrosionsverhalten

Hinsichtlich der Anwendungsgebiete ist seine Beständigkeit gegenüber Trink- und Brauchwasser (auch aggressive Wässer), Kondenswasser, Wasserdampf, nicht oxidierende Säuren, neutrale Salzlösungen und vor allem gegen Meerwasser von besonderer Bedeutung.

*est parfaitement possible d'associer l'acier inoxydable, le cuivre, le cuivre à intérieur zingué et les alliages de cuivre.*

*En principe, pour la conception et la fabrication des conduites, il convient de respecter les règles généralement reconnues de la technique pour chaque corps de métier (p. ex. DIN EN 806 et DIN 1988 pour les installations d'eau potable).*

### Champs d'application

- *Systèmes de distribution d'eau potable pour eau potable froide et chaude*
- *Systèmes de chauffage et de refroidissement y compris les systèmes au sol, au mur et au plafond*
- *Distribution de combustibles gazeux et liquides*
- *Centrales solaires thermiques*
- *Conduites d'eau d'incendie et systèmes d'arrosage automatique*
- *Installations d'air comprimé*
- *Installations pour la distribution de gaz techniques*
- *Eau de pluie et de traitement*
- *Applications commerciales et industrielles (hydraulique, pneumatique)*
- *Eaux usées (p. ex. conduites pour stations de relevage)*

### Tenue à la corrosion

*Pour ce qui est des champs d'applications, la résistance est particulièrement importante à l'eau potable et non potable (y compris à l'eau corrosive), à l'eau condensée, à la vapeur d'eau, aux acides non oxydants, aux solutions salines neutres et surtout à l'eau de mer.*

zincato all'interno e leghe di rame.

Nel progettare e realizzare tubazioni, si dovranno in linea generale tenere in considerazione le regole generalmente riconosciute della tecnica per la singola opera (per gli impianti di acqua potabile, per esempio, le norme DIN EN 806 e DIN 1988).

### Ambiti di applicazione

- Sistemi di distribuzione di acqua potabile per acqua potabile fredda e riscaldata
- Sistemi di riscaldamento e raffreddamento, compresi i sistemi a pavimento, a parete e a soffitto
- Distribuzione di combustibili allo stato gassoso e liquido
- Impianti solari termici
- Tubature dell'acqua di spegnimento e impianti antincendio
- Impianti ad aria compressa
- Impianti per la distribuzione di gas tecnici
- Acqua piovana e acqua per processi industriali
- Applicazioni in ambienti commerciali e industriali (idraulica, pneumatica)
- Acque reflue (es. tubi a pressione per impianti di sollevamento delle acque reflue)

### Comportamento in materia di corrosione

Considerati gli ambiti di applicazione, la resistenza dei nostri prodotti all'acqua potabile e sanitaria (anche ad acque aggressive), all'acqua di condensa, al vapore acqueo, ad acidi non ossidanti, a soluzioni saline neutre e soprattutto all'acqua marina è particolarmente importante.

**Einsatzbereiche INOX-Gewindefittings**

Anwendung*	Durchflussmedium	Druck bar	Temperatur °C
Trinkwasser-Installationen DIN EN 806 und DIN 1988	Trinkwasser gemäss Trinkwasserverordnung	10 16	95 25
Warmwasser-Heizungen DIN EN 12828	Heizungswasser VDI 2035-1	6	110
Nah- und Fernwärmeleitungen DIN 4747	Heizungs- bzw. Fernwärmewasser VDI 2035-1 bzw. AGFW FW 510	10	110
Thermische Solaranlagen mit permanenten Betriebstemperaturen ≤ 110 °C DIN EN 12975/12976	Wasser und Wasser-Glykol-Gemische Mischungsverhältnis max. 50/50 %	6	-35 bis 110 180 ≤ 30 h/a 200 ≤ 10 h/a
Wassergeführte Raumkühlanlagen	Wasser und Wasser-Glykol-Gemische Mischungsverhältnis max. 50/50 %	6	-10
Regenwassernutzungsanlagen DIN 1989	Regenwasser aus Zisternen	10	25
Feuerlöschleitungen «nass» DIN 14462	Löschwasser	16	25
Druckluft ölfrei	Druckluft Klassen 1 - 3 gemäss ISO 8573-1	10	25
Industrie- und Prozesswässer	Aufbereitete, enthärtete, teil- und vollentsalzte Wässer**	10 16	95 25
Vakuumentleitungen für nichtmedizinische Zwecke		-0,8	Raumtemperatur
Baustellenprüfdruck	Baustellenprüfdruck	16	20

\* Weitere Anwendungen sind möglich. Bitte kontaktieren Sie unsere technische Beratung  
 \*\* Wir empfehlen eine kostenlose Einzelfallprüfung durch unsere technische Beratung vornehmen zu lassen.

Temperatur °C – Température – Temperatura	Maximaldruck bar – Pression max. bars – Pressione massima bar
-20 - 40	20
100	16.5
150	15
200	14
220	13.5

Die obigen Werte dienen als Richtwerte; abhängig vom Medium, etc.  
 Les valeurs ci-dessus sont données à titre indicatif, en fonction du fluide.  
 I valori sopra indicati servono da valori indicativi, a seconda del prodotto

**Desinfektion & Korrosionsschutz**

Der von uns verwendete Edelstahl weist nach Norm einen Molybdän-Gehalt von mindestens 2 % auf, so dass eine sehr gute Chloridbeständigkeit gegeben ist.

Für Trinkwässer gilt innerhalb der EU ein Chlorid-Grenzwert von 250 mg/l. Der Chlorid-Gehalt von anderen Wässern (z. B. Prozesswässer) sollte beim Einsatz von Inox 600 mg/l nicht übersteigen.

Eine chemische Desinfektion von mit Inox erstellten Rohrsystemen ist ohne Probleme möglich. Hierbei sind die Vorgaben der TrinkwV und des DVGW-Arbeitsblatts W 557 einzuhalten.

Rohrleitungen aus Edelstahl werden bevorzugt mit Wasserstoffperoxid H2O2 desinfiziert, die Desinfektion mit Chlor ist ebenfalls möglich.

Edelstahlrohrleitungen sind vor äusserem Kontakt mit stark chloridhaltigen Baustoffen und anderen aggressiven Medien zu schützen.

In derartigen Fällen kann ein nachträglicher Korrosionsschutz nach DIN EN 12068 mittels Korrosionsschutzbinden und/oder Schrumpfschläuchen der Beanspruchungsklassen A oder B vorgesehen werden. Im Zweifelsfall empfehlen wir die Kontaktaufnahme mit unserer technischen Beratung.

## Champs d'application des raccords en acier inoxydable

Application*	Fluide acheminé	Pression bars	Température °C
Installations d'eau potable DIN EN 806 et DIN 1988	Eau potable selon le décret sur l'eau potable	10 16	95 25
Chauffages à l'eau chaude DIN EN 12828	Eau de chauffage VDI 2035-1	6	110
Conduites de chauffage local et urbain DIN 4747	Eau de chauffage ou eau de chauffage urbain VDI 2035-1 et AGFW FW 510	10	110
Centrales solaires thermiques avec températures constantes de service ≤ 110 °C DIN EN 12975/12976	Eau et mélanges eau-glycol Proportion du mélange max. 50/50 %	6	De -35 à 110 180 ≤ 30 h/a 200 ≤ 10 h/a
Systèmes de refroidissement des locaux à l'eau	Eau et mélanges eau-glycol Proportion du mélange max. 50/50 %	6	-10
Installations d'exploitation de l'eau de pluie DIN 1989	Eau de pluie des citernes	10	25
Canalisations d'eau pour extinction d'incendie, «voie humide» DIN 14462	Eau d'extinction d'incendie	16	25
Air comprimé sans huile	Air comprimé catégories 1 à 3 selon ISO 8573-1	10	25
Eau industrielle et de processus	Eau traitée, adoucie, en partie ou intégralement dessalée**	10 16	95 25
Conduites à vide pour utilisations non médicales		-0,8	Température ambiante
Pression d'essai chantier	Pression d'essai chantier	16	20

\*D'autres utilisations sont possibles. Contactez notre conseil technique.

\*\*Nous recommandons de faire réaliser un test gratuit d'erreur occasionnelle par notre conseil technique.

Temperatur °C – Température – Temperatura	Maximaldruck bar – Pression max. bars – Pressione massima bar
-20 - 40	20
100	16.5
150	15
200	14
220	13.5

Die obigen Werte dienen als Richtwerte; abhängig vom Medium, etc.  
Les valeurs ci-dessus sont données à titre indicatif, en fonction du fluide.  
I valori sopra indicati servono da valori indicativi, a seconda del prodotto

### Désinfection et protection anticorrosion

L'acier inoxydable que nous utilisons présente une teneur en molybdène d'au moins 2 %, conformément à la norme, garantissant une très bonne résistance au chlorure.

Au sein de l'UE, la valeur seuil de chlorure est fixée à 250 mg/l. La teneur en chlorure des autres sortes d'eau (p. ex. l'eau de processus) ne doit pas dépasser 600 mg/l en cas d'utilisation d'acier inoxydable.

Une désinfection chimique des systèmes de tubes fabriqués avec de l'acier inoxydable est parfaitement possible. Il convient alors de respecter les directives du décret sur l'eau potable (TrinkwV) et de la feuille de travail W 557 du DVGW.

Il est préférable de désinfecter les conduites en acier inoxydable au peroxyde d'hydrogène, une désinfection au chlore est également possible.

Les conduites en acier inoxydable doivent être protégées du contact extérieur avec des matériaux de construction contenant du chlorure et d'autres fluides agressifs.

Le cas échéant, une protection anticorrosion ultérieure selon DIN EN 12068 peut être envisagée à l'aide de bandages anticorrosion ou de gaines rétrécissables de catégorie de résistance A ou B. En cas de doute, contactez notre conseil technique.

## Campi di utilizzo dei raccordi filettati in acciaio inossidabile

Applicazione*	Mezzo fluido contenuto	Pressione bar	Temperatura °C
Impianti acqua potabile DIN EN 806 e DIN 1988	Acqua potabile come da direttiva sull'acqua potabile	10 16	95 25
Riscaldamento acqua calda DIN EN 12828	Acqua di riscaldamento VDI 2035-1	6	110
Tubi per riscaldamento e teleriscaldamento DIN 4747	Acqua per riscaldamento e teleriscaldamento VDI 2035-1 e AGFW FW 510	10	110
Impianti solari termici con temperature di esercizio permanenti ≤ 110 °C DIN EN 12975/12976	Acqua e miscele di acqua e glicole Rapporto di miscelazione max. 50/50%	6	Da -35 a 110 180 ≤ 30 h/a 200 ≤ 10 h/a
Impianti di raffreddamento ad acqua	Acqua e miscele di acqua e glicole Rapporto di miscelazione max. 50/50%	6	-10
Impianti di riutilizzo dell'acqua piovana DIN 1989	Acqua piovana proveniente da cisterne	10	25
Tubi antincendio «ad umido» DIN 14462	Acqua di spegnimento	16	25
Aria compressa senza olio	Aria compressa classi 1 – 3 secondo la ISO 8573-1	10	25
Acqua industriale e di processi industriali	Acqua pretrattata, decalcificata, parzialmente o totalmente desalinizzata**	10 16	95 25
Tubi per vuoto, per applicazioni non mediche		-0,8	Temperatura ambiente
Pressione di collaudo in cantiere	Pressione di collaudo in cantiere	16	20

\*Sono possibili altre applicazioni – contattare i nostri consulenti tecnici.

\*\*Si raccomanda di far effettuare una prova gratuita dell'applicazione specifica ai nostri consulenti tecnici.

Temperatur °C	Maximaldruck bar
-20 - 40	20
100	16.5
150	15
200	14
220	13.5

Die obigen Werte dienen als Richtwerte; abhängig vom Medium, etc.

### Disinfezione e protezione dalla corrosione

L'acciaio inossidabile da noi utilizzato presenta un contenuto minimo di molibdeno del 2%, come da norma, valore che garantisce un'ottima resistenza al cloro.

Per l'acqua potabile si applica all'interno dell'UE un valore limite di cloro di 250 mg/l. Il contenuto di cloro di altre acque (ad es. quelle dei processi industriali) non dovrebbe superare i 600 mg/l se si utilizza l'acciaio inossidabile.

I sistemi di tubi prodotti con l'acciaio inossidabile possono essere sottoposti a disinfezione chimica senza problemi. Per tale operazione si dovranno osservare le prescrizioni del regolamento sull'acqua potabile (TrinkwV) e del foglio di lavoro DVGW W 557.

Le tubazioni in acciaio inossidabile vengono disinfettate preferibilmente con perossido di idrogeno H<sub>2</sub>O<sub>2</sub>, è possibile anche la disinfezione con cloro.

Le tubazioni in acciaio inossidabile devono essere protette dal contatto esterno con materiali ad alto contenuto di cloro e da altre sostanze aggressive.

In questi casi è possibile prevedere una protezione anticorrosione da applicarsi a posteriori, conformemente alla norma DIN EN 12068, mediante fascette anticorrosione e/o manicotti a restringere delle classi di sollecitazione A o B. In caso di dubbi si raccomanda di contattare i nostri consulenti tecnici.



Anwendungen Applications Applicazioni		
Zulassung Autorisation Omologazione	SVGW geprüft gemäss Zertifikat Nr. 1709-6667 Contrôlé par le SVGW et autorisé selon certificat No. 1709-6667 Sottoposto a prove e omologato SVGW ai sensi del certificato Nr. 1709-6667	
Eigenschaften Propriétés Proprietà	Warmwasser-, chemikalien- und alterungsbeständig Résistant à l'eau chaude, aux produits chimiques et au vieillissement Resistente all'acqua calda, alle sostanze chimiche e all'usura	
Einsatzbereich Champ d'application Campo di impiego	Regenwasser Eau de pluie Acqua piovana	Sanitär/Heizung Sanitaire/chauffage Sanitari/riscaldamento
Max. Betriebstemperatur Température max. de service Temperatura di esercizio max.	30° C	95° C
Max. Betriebsdruck Pression max. de service Pressione di esercizio max.	16 bar(s)	20 bar(s) siehe Tabelle Seite 6 / selon table sur la page 7 / secondo tavolo p. 8

Anwendungen Applications Applicazioni	Rohr Edelstahl Tube acier inoxydable Tubo acciaio inox	Rohr Stahl Tube acier Tubo acciaio	Druck bar Pression bar Pressione bar	Temperatur °C Température °C Temperatura °C
Trinkwasser-Installationen – DIN EN 806 und DIN 1988 Installations d'eau potable – DIN EN 806 et DIN 1988 Impianti acqua potabile – DIN EN 806 e DIN 1988	✓		16	95 25
Warmwasser-Heizungen – DIN EN 12828 Chauffages à l'eau chaude – DIN EN 12828 Riscaldamento acqua calda – DIN EN 12828	✓	✓	16	110
Nah- und Fernwärmeleitungen – DIN 4747 Conduites de chauffage local et urbain – DIN 4747 Tubi per riscaldamento e teleriscaldamento – DIN 4747	✓	✓	16	110
Thermische Solaranlagen – DIN EN 12975/12976 Centrales solaires thermiques – DIN EN 12975/12976 Impianti solari termici – DIN EN 12975/12976	✓	✓	6	150 (kurz 200) (pour une courte durée 200) (per breve tempo 200)
Wassergeführte Raumkühlanlagen Systèmes de refroidissement des locaux à l'eau Impianti di raffreddamento ad acqua	✓	✓	16	-20
Regenwassernutzungsanlagen – DIN 1989 Löschwasserleitungen «nass» – DIN 14462 Installations d'exploitation de l'eau de pluie – DIN 1989 Canalisations d'eau pour extinction d'incendie, «voie humide» – DIN 14462 Impianti di riutilizzo dell'acqua piovana – DIN 1989 Tubi antincendio «ad umido» – DIN 14462	✓		16	25
Druckluft Air comprimé Aria compressa	✓	✓	7	25
Industrie- und Prozesswässer Eau industrielle et de processus Acqua industriale e di processi industriali	✓		16	95 25
Heizölversorgungsanlagen – DIN 4755 TRÖ Installations d'alimentation en mazout – DIN 4755 TRO Impianti a gasolio – DIN 4755 TRO	✓	✓	6	25

Montageanleitung – Instructions de montage – Istruzioni di montaggio











Rohr ablängen und Gewinde schneiden  
Couper le tube et fraisez le filetage  
Tagliare il tubo e svasare la filettatura

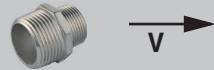

Gewinde einhanfen  
Enrober le filetage avec du chanvre  
Rivestire la filettatura canapa



Fitting anziehen mit geeignetem Werkzeug  
Vissent avec l'outil adéquat  
Vite con un attrezzo adatto

Einzelwiderstand je Typ valeur de résistance par type valore di resistenza per tipo	Nr. nombre numero	Artikel article articolo	Fittingtyp / Symbol + Fließrichtung** type de raccord / symboles** tipo di montaggio / simboli**	ζ- Wert* ζ- valeur* ζ- valore*
	1	Muffe manchon manicotto		0,3
	2	Doppelnippel reduziert *** mamelon réduit *** bocciolo ridotto ***		0,4
	3	Reduziermuffe *** manchon réduit *** manicotto ridotto ***		0,3
	4	Winkel 90° coude 90° gomito 90°		1,0
	5	Winkel 90° IG/AG coude 90° f/m gomito 90° f/m		1,4
	6	Winkel 45° coude 45° gomito 45°		0,6
	7	T-Stück Abzweig té jonction tee giunzione		1,5
	8	T-Stück Durchgang té passage tee passaggio		0,3
	9	Rohrverschraubung union conique bocchetone conico		0,5

\* Basiswerte als Auszug aus dem HSLU, Prüfstelle Gebäudetechnik, Prüfbericht HP-171717  
Bezug auf Dimension 1", bei v= 2m/s (für kleiner Dimensionen und Geschwindigkeiten sind bis +50% Zuschlag einzurechnen)  
Valeurs de base tirées du rapport d'essai HP-171717, Laboratoire de technique du bâtiment, Haute école de Lucerne  
Valeur de référence pour la dimension 1" pour v = 2m/s (compter +50% de supplément pour les dimensions et vitesses inférieures)  
Valori di base estratti dal rapporto di prova HP-171717 del Centro di prova Tecnica degli edifici della HSLU (scuola universitaria professionale lucernese).  
Riferimento alla dimensione 1", con v= 2m/s (per dimensioni e velocità inferiori occorrerà calcolare un supplemento fino a +50%).

\*\* Das Formelzeichen V für Fließgeschwindigkeit gibt den Ort der maßgebenden Bezugsgeschwindigkeit im Formteil an  
Le symbole v de la vitesse d'écoulement indique l'emplacement de la vitesse de référence déterminante dans la pièce moulée.  
Il simbolo v (=velocità di flusso) contenuto nella formula indica il punto della velocità di riferimento nello stampo.

\*\*\* Reduzierungen basieren auf bis zu 2 Dimensions-Sprüngen  
Les réductions se déclinent en 2 dimensions max.  
Le riduzioni si basano su incrementi di un massimo di 2 dimensioni.

Edelstahl-Gewinderohr geschweisst, dickwandig,  
ungeglüht, 1.4404 / V4A  
Tube en acier inox, à parois épaisses non recuit  
- 1.4404 / V4A  
Tubo filettato in acciaio inox saldato, a pareti  
spesse, non ricotta - 1.4404 / V4A



Zoll Pouce Pollice	mm	L	WS	kg	Art.-Nr. No. Art.	Verp.-Einh. Unité Emb. Unità lmb.	CHF netto CHF net /m
1/8	10.2	6000	1.5	0.32	82697	6	auf Anfrage
1/4	13.5	6000	1.6	0.48	82698	6	auf Anfrage
3/8	17.2	6000	2.3	0.86	82699	6	auf Anfrage
1/2	21.3	6000	1.6	0.78	82700	6	auf Anfrage
3/4	26.9	6000	2.6	1.58	82701	6	auf Anfrage
1	33.7	6000	3.2	2.31	82702	6	auf Anfrage
1-1/4	42.4	6000	3.2	3.15	82703	6	auf Anfrage
1-1/2	48.3	6000	3.2	3.62	82704	6	auf Anfrage
2	60.3	6000	3.6	5.13	82705	6	auf Anfrage
2-1/2	76.1	6000	3.6	6.56	82706	6	auf Anfrage
3	88.9	6000	3.6	7.72	82707	6	auf Anfrage
4	114.3	6000	3.6	10.02	82708	6	auf Anfrage

Edelstahl-Gewinderohr geschweisst, dickwandig,  
ungeglüht, 1.4307 / V2A  
Tube en acier inox à parois épaisses, non recuit -  
1.4307 / V2A  
Tubo filettato in acciaio inox saldato, a pareti  
spesse, non ricotta - 1.4307 / V2A



Zoll Pouce Pollice	mm	L	WS	kg	Art.-Nr. No. Art.	Verp.-Einh. Unité Emb. Unità lmb.	CHF netto CHF net /m
1/8	10.2	6000	1.5	0.32	82720	6	auf Anfrage
1/4	13.5	6000	1.6	0.48	82721	6	auf Anfrage
3/8	17.2	6000	2.3	0.86	82722	6	auf Anfrage
1/2	21.3	6000	2.6	1.22	82723	6	auf Anfrage
3/4	26.9	6000	2.6	1.58	82724	6	auf Anfrage
1	33.7	6000	3.2	2.45	82725	6	auf Anfrage
1-1/4	42.4	6000	3.2	3.15	82726	6	auf Anfrage
1-1/2	48.3	6000	3.2	3.62	82727	6	auf Anfrage
2	60.3	6000	3.6	5.13	82728	6	auf Anfrage
2-1/2	76.1	6000	3.6	6.56	82729	6	auf Anfrage
3	88.9	6000	4	8.53	82730	6	auf Anfrage
4	114.3	6000	3.6	10.02	82731	6	auf Anfrage

Muffe Edelstahl 316  
Manchon acier inoxydable 316  
Manicotto acciaio inossidabile 316

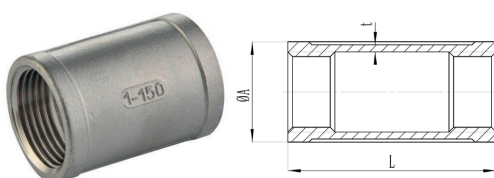

Zoll Pouce Pollice	A	L	T	Art.-Nr. No. Art.	Verp.-Einh. Unité Emb. Unità lmb.	CHF/ Stück Pièce Pezzo
1/8"	14.5	17	1.6	82070	5	1.60
1/4"	18	24	1.6	82071	5	1.80
3/8"	21.5	25	1.6	82072	5	2.00
1/2"	26	32	1.8	82073	5	2.00
3/4"	31.5	35	1.8	82074	5	2.80
1"	39	55	2	82075	2	5.50
1 1/4"	48	65	2.4	82076	2	8.30
1 1/2"	55	65	2.5	82077	1	11.00
2"	67.5	70	2.8	82078	1	15.80
2 1/2"	84	75	3.3	82079	1	29.60
3"	98.5	80	3.8	82080	1	36.90
4"	124.5	92	4.3	82081	1	59.30

**Doppelnippel Edelstahl 316**  
*Mamelon double acier inoxydable 316*  
*Bocciolo doppio acciaio inossidabile 316*

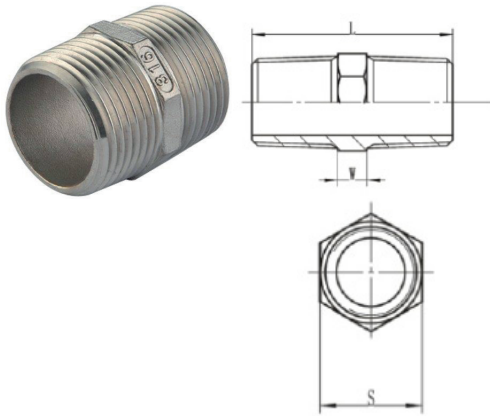

Zoll Pouce Pollice	L	W	S	Art.-Nr. No. Art.	Verp.-Einh. Unité Emb. Unità Imb.	CHF/ Stück Pièce Pezzo
1/8"	20	4	11	81999	5	1.60
1/4"	25	4	14.6	82000	5	1.70
3/8"	27	5	18.5	82001	5	1.80
1/2"	34	5	22.5	82002	5	1.90
3/4"	36.5	5.5	28	82003	5	2.60
1"	42	6	34	82004	2	4.40
1 1/4"	47.5	6.5	44	82005	2	6.90
1 1/2"	47.5	6.5	50	82006	2	8.60
2"	57	7	62	82007	1	14.20
2 1/2"	61	7	78	82008	1	21.80
3"	67.5	7.5	90.5	82009	1	31.40
4"	80	8	116.5	82010	1	55.40

**Doppelnippel reduziert AG/AG Edelstahl 316**  
*Mamelon réduit m/m acier inoxydable 316*  
*Bocciolo ridotto m/m acciaio inossidabile 316*

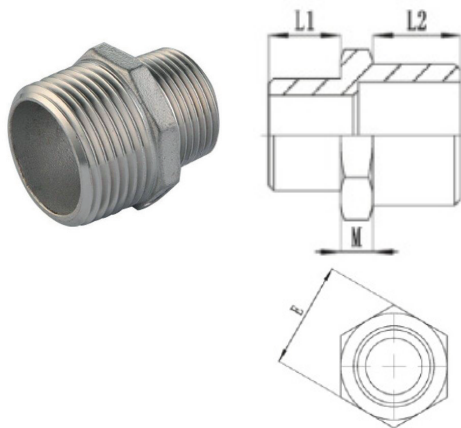

Zoll Pouce Pollice	L1	M	L2	E	Art.-Nr. No. Art.	Verp.-Einh. Unité Emb. Unità Imb.	CHF/ Stück Pièce Pezzo
1/4" x 1/8"	8	4	10.5	14.5	82440	5	1.70
3/8" x 1/8"	8	5	11	18	82441	5	1.80
3/8" x 1/4"	10.5	5	11	18	82442	5	2.00
1/2" x 1/8"	8	8	14.5	22	82443	5	2.20
1/2" x 1/4"	11	5	14.5	22	82444	5	2.40
1/2" x 3/8"	10.5	5.5	14.5	22	82445	5	2.80
3/4" x 1/4"	11	5.5	15.5	28	82446	5	2.90
3/4" x 3/8"	14.5	5.5	15.5	28	82447	5	3.00
3/4" x 1/2"	14.5	5.5	15.5	28	82448	5	2.50
1" x 1/4"	11	6	15.5	35	82449	5	4.50
1" x 3/8"	15.5	6	15.5	35	82450	5	3.50
1" x 1/2"	14.5	6	18	35	82451	5	4.30
1" x 3/4"	15.5	6	18	35	82452	5	4.00
1 1/4" x 1/2"	14.5	6.5	20.5	43.5	82453	5	9.60
1 1/4" x 3/4"	15.5	6.5	20.5	43.5	82454	5	5.80
1 1/4" x 1"	18	6.5	20.5	43.5	82455	5	6.50
1 1/2" x 1/2"	14.5	6.5	20.5	49	82456	5	9.60
1 1/2" x 3/4"	15.5	6.5	20.5	49	82457	5	9.60
1 1/2" x 1"	18	6.5	20.5	49	82458	5	7.40
1 1/2" x 1 1/4"	20.5	6.5	20.5	49	82459	5	10.20
2" x 1/2"	14.5	7	25	62	82460	2	15.10
2" x 3/4"	15.5	7	25	61.5	82461	2	15.10
2" x 1"	18	7	25	61.5	82462	2	15.10
2" x 1 1/4"	20.5	7	25	61.5	82463	2	12.50
2" x 1 1/2"	20.5	7	25	61.5	82464	2	13.00
2 1/2" x 1 1/2"	20.5	7	27	77	82465	1	32.30
2 1/2" x 2"	25	7	27	77	82466	1	19.30
3" x 2"	25	7.5	30	90.5	82467	1	33.30
3" x 2 1/2"	27	7.5	30	90.5	82468	1	29.40
4" x 2"	25	8	36	116	82469	1	65.60
4" x 2 1/2"	27	8	36	116.5	82470	1	49.00
4" x 3"	30	8	36	116.5	82471	1	49.90

**Reduziermuffe Edelstahl 316**  
**Manchon réduit acier inoxydable 316**  
**Manicotto ridotto acciaio inossidabile 316**

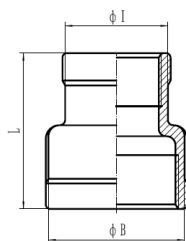

Zoll Pouce Pollice	I	B	L	Art.-Nr. No. Art.	Verp.-Einh. Unité Emb. Unità Imb.	CHF/ Stück Pièce Pezzo
1/4" x 1/8"	14	18	25	82500	5	1.70
3/8" x 1/8"	14	21.5	26	82501	5	1.80
3/8" x 1/4"	17.5	21.5	26	82502	5	2.10
1/2" x 1/8"	17.5	21.5	26	82503	5	2.20
1/2" x 1/4"	17.5	26	34	82504	5	2.20
1/2" x 3/8"	21	26	34	82505	5	2.00
3/4" x 1/4"	17.5	31.5	36	82506	5	2.50
3/4" x 3/8"	21	31.5	36	82507	5	2.60
3/4" x 1/2"	25.5	31.5	36	82508	5	3.40
1" x 1/4"	16.5	37.5	42	82509	5	3.90
1" x 3/8"	20	39	42	82510	5	4.40
1" x 1/2"	25.5	39	42	82511	5	4.80
1" x 3/4"	31	39	42	82512	5	5.00
1 1/4" x 1/4"	31	39	42	82513	2	7.00
1 1/4" x 3/8"	20	46.5	48	82514	2	8.10
1 1/4" x 1/2"	20	48	48	82515	2	6.60
1 1/4" x 3/4"	31	48	48	82516	2	6.30
1 1/4" x 1"	39	48	48	82517	2	7.80
1 1/2" x 3/8"	20	53	52	82518	2	7.80
1 1/2" x 1/2"	24.5	55	52	82519	2	8.60
1 1/2" x 3/4"	30	55	52	82520	2	8.70
1 1/2" x 1"	37.5	55	52	82521	2	10.10
1 1/2" x 1 1/4"	46.5	55	52	82522	2	10.30
2" x 1/2"	24.5	68	45	82523	2	10.30
2" x 3/4"	30	67.5	58	82524	2	13.60
2" x 1"	37.5	67.5	58	82525	1	14.60
2" x 1 1/4"	46.5	67.5	58	82526	1	13.20
2" x 1 1/2"	53	67.5	58	82527	1	14.80
2 1/2" x 1"	37.5	81	65	82528	1	23.20
2 1/2" x 1 1/4"	46.5	81	65	82529	1	23.00
2 1/2" x 1 1/2"	53	81	65	82530	1	23.20
2 1/2" x 2"	63.5	81	65	82531	1	24.50
3" x 1 1/4"	46.5	95.5	72	82532	1	33.40
3" x 1 1/2"	53	95.5	72	82533	1	39.60
3" x 2"	65.5	95.5	72	82534	1	36.60
3" x 2 1/2"	82	95.5	72	82535	1	39.60
4" x 1 1/2"	53	121.5	94	82536	1	54.10
4" x 2"	65.5	121.5	94	82537	1	56.90
4" x 2 1/2"	82	121.5	94	82538	1	59.80
4" x 3"	95.5	121.5	94	82539	1	66.60

**Reduzierstück IG/AG Edelstahl 316**  
**Mamelon réduit f/m acier inoxydable 316**  
**Bocciolo ridotto f/m acciaio inossidabile 316**

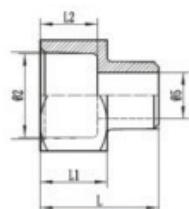

Zoll Pouce Pollice	Ø 2	L1	L2	L	Ø 5	H	Art.-Nr. No. Art.	Verp.-Einh. Unité Emb. Unità Imb.	CHF/ Stück Pièce Pezzo
1/2" x 3/8"	17.3	18.5	16.6	30.5	11.8	24	82432	5	2.50
3/4" x 1/2"	22.7	21	17.5	37.7	15.2	30.2	82433	5	4.20
1" x 3/4"	28.3	23	20.9	39.6	20	36.9	82434	5	5.50
1 1/4" x 1"	38.4	22.3	19.7	40.6	26.8	54.3	82435	5	6.80
1 1/2" x 1 1/4"	4.6	27.2	24.6	48.5	54.3	52.1	82436	2	10.50
2" x 1 1/2"	54.5	30.7	27	52.4	40.8	63.2	82437	1	14.90

Reduziernippel AG/IG Edelstahl 316  
 Mamelon réduit m/f acier inoxydable 316  
 Bocciolo ridotto m/f acciaio inossidabile 316

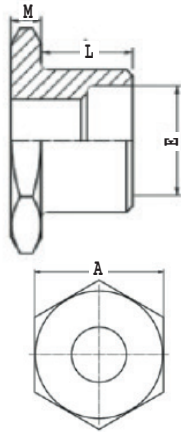

Zoll Pouce Pollice		A	E	L	M	Art.-Nr. No. Art.	Verp.- Einh. Unité Emb. Unità lmb.	CHF/ Stück Pièce Pezzo
1/4" x 1/8"	6	14.5	8	10.5	4	82390	5	1.60
3/8" x 1/8"	6	18.5	11.5	11	5	82391	5	1.80
3/8" x 1/4"	6	18.5	11.5	11	5	82392	5	2.00
1/2" x 1/8"	6	22.5	15	14.5	5	82393	5	2.20
1/2" x 1/4"	6	22.5	15	14.5	5	82394	5	2.40
1/2" x 3/8"	6	22.5	15	14.5	5	82395	5	2.60
3/4" x 1/8"	8	28	20.5	15.5	5.5	82396	5	2.70
3/4" x 1/4"	8	28	20.5	15.5	5.5	82397	5	2.60
3/4" x 3/8"	8	28	20.5	15.5	5.5	82398	5	2.10
3/4" x 1/2"	8	28	20.5	15.5	5.5	82399	5	2.10
1" x 1/8"	8	35	26	18	6	82400	5	4.10
1" x 1/4"	8	35	26	18	6	82401	5	4.40
1" x 3/8"	8	35	26	18	6	82402	5	4.10
1" x 1/2"	8	35	26	18	6	82403	5	3.50
1" x 3/4"	8	35	26	18	6	82404	5	3.40
1 1/4" x 1/2"	8	44	34.5	20.5	6.5	82405	5	6.40
1 1/4" x 3/4"	8	44	34.5	20.5	6.5	82406	5	6.00
1 1/4" x 1"	8	44	34.5	20.5	6.5	82407	5	5.00
1 1/2" x 1/2"	8	49.5	40	20.5	6.5	82408	5	9.30
1 1/2" x 3/4"	8	49.5	40	20.5	6.5	82409	5	8.00
1 1/2" x 1"	8	49.5	40	20.5	6.5	82410	5	7.80
1 1/2" x 1 1/4"	8	49.5	40	20.5	6.5	82411	5	5.20
2" x 1/2"	8	61.5	51	25	7	82412	2	15.50
2" x 3/4"	8	61.5	51	25	7	82413	2	15.80
2" x 1"	8	61.5	51	25	7	82414	2	13.30
2" x 1 1/4"	8	61.5	51	25	7	82415	2	11.50
2" x 1 1/2"	8	61.5	51	25	7	82416	2	10.10
2 1/2" x 1/2"	8	61.5	51	25	7	82417	2	25.70
2 1/2" x 3/4"	8	61.5	51	25	7	82418	2	20.20
2 1/2" x 1"	8	61.5	51	25	7	82419	2	22.50
2 1/2" x 1 1/4"	8	61.5	51	25	7	82420	2	22.40
2 1/2" x 1 1/2"	10	77.5	65.5	27	7	82421	1	19.50
2 1/2" x 2"	10	77.5	65.5	27	7	82422	1	19.20
3" x 3/4"	10	90.5	77.5	30	7.5	82423	1	41.80
3" x *1"	10	90.5	77.5	30	7.5	82424	1	37.50
3" x 1 1/4"	10	90.5	77.5	30	7.5	82425	1	34.80
3" x 1 1/2"	10	90.5	77.5	30	7.5	82426	1	36.50
3" x 2"	10	90.5	77.5	30	7.5	82427	1	27.40
3" x 2 1/2"	10	90.5	77.5	30	7.5	82428	1	21.80
4" x 2"	10	116.5	101.5	36	8	82429	1	63.50
4" x 2 1/2"	10	116.5	101.5	36	8	82430	1	50.80
4" x 3"	10	116.5	101.5	36	8	82431	1	44.80

## Legende für Gewinde

## Légende pour le fil

## Legenda per filo

1/8" - 1/2"	6	Hexagon 6 Kt
3/4" - 2"	8	Octagon 8 Kt
2 1/2" - 4"	10	Decagon 10 Kt

**Gewindemuffe Edelstahl 316**  
*Manchon fileté acier inoxydable 316*  
*Manicotto filettato acciaio inossidabile 316*

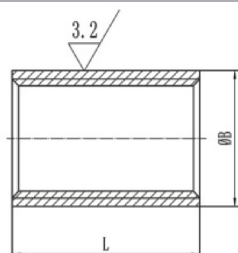
ISO  
4144

Zoll Pouce Pollice	L	B	Art.-Nr. No. Art.	Verp.-Einh. Unité Emb. Unità Imb.	CHF/ Stück Pièce Pezzo
1/8"	17	13	82600	5	1.20
1/4"	24	16.5	82601	5	1.60
3/8"	25	20	82602	5	1.80
1/2"	32	24.5	82603	5	2.60
3/4"	35	30	82604	5	3.30
1"	41	37	82605	5	5.00
1 1/4"	45	46.5	82606	2	7.10
1 1/2"	45	53	82607	2	8.20
2"	54	65	82608	2	12.00
2 1/2"	63	81.5	82609	1	20.00
3"	69	95	82610	1	26.40
4"	81	121.5	82611	1	42.50

**Gewindemuffe kurz Edelstahl 316**  
*Manchon court fileté acier inoxydable 316*  
*Manicotto breve filettato acciaio inossidabile 316*

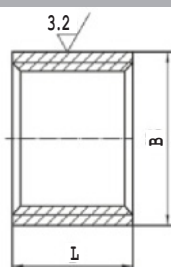
ISO  
4144

Zoll Pouce Pollice	L	B	Art.-Nr. No. Art.	Verp.-Einh. Unité Emb. Unità Imb.	CHF/ Stück Pièce Pezzo
1/8"	7.5	13	82620	5	0.90
1/4"	11	16.5	82621	5	1.10
3/8"	11.5	20	82622	5	1.20
1/2"	15	24.5	82623	5	1.70
3/4"	16.5	30	82624	5	2.10
1"	19.5	37	82625	5	3.00
1 1/4"	21.5	46.5	82626	5	4.20
1 1/2"	21.5	53	82627	5	4.90
2"	26	65	82628	2	6.90
2 1/2"	30.5	81.5	82629	2	11.60
3"	33.5	95	82630	1	15.20
4"	39.5	121.5	82631	1	23.80

**Gewindenippel Edelstahl 316**  
*Mamelon fileté acier inoxydable 316*  
*Nipplo filettato acciaio inossidabile 316*

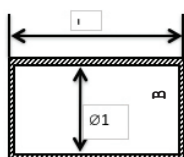

L

Zoll Pouce Pollice	L	Ø 1	Art.-Nr. No. Art.	Verp.-Einh. Unité Emb. Unità Imb.	CHF/ Stück Pièce Pezzo
3/8"	3.2	12.95 ± 0.2	82640	5	2.20
1/2"	3.5	16.34 ± 0.2	82641	5	2.70
3/4"	4.0	21.67 ± 0.2	82642	5	3.40
1"	4.0	27.40 ± 0.2	82643	5	4.30
1 1/4"	5.1	35.76 ± 0.2	82644	5	6.50
1 1/2"	5.1	41.66 ± 0.2	82645	3	7.90
2"	5.1	53.33 + 0.2 - 0.4	82646	3	9.90

**Langnippel Edelstahl 316**  
*Mamelon double longue acier inoxydable 316*  
*Bocciolo doppio lunghi acciaio inossidabile 316*

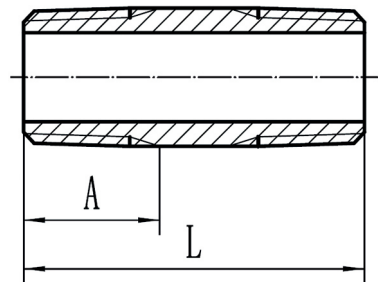

Zoll Pouce Pollice	A	L	Art.-Nr. No. Art.	Verp.-Einh. Unité Emb. Unità Imb.	CHF/ Stück Pièce Pezzo
1/8"	8	40	82753	5	CHF 1.30
1/8"	8	60	82755	5	CHF 1.50
1/8"	8	80	82757	5	CHF 1.70
1/8"	8	100	82759	5	CHF 1.90
1/8"	8	120	82761	5	CHF 2.10
1/4"	11	40	82783	5	CHF 1.40
1/4"	11	60	82785	5	CHF 1.40
1/4"	11	80	82787	5	CHF 1.60
1/4"	11	100	82789	5	CHF 1.80
1/4"	11	120	82791	5	CHF 2.00
3/8"	12	30	82812	5	CHF 1.20
3/8"	12	40	82813	5	CHF 1.50
3/8"	12	50	82814	5	CHF 1.50
3/8"	12	60	82815	5	CHF 1.70
3/8"	12	70	82816	5	CHF 1.90
3/8"	12	80	82817	5	CHF 2.00
3/8"	12	90	82818	5	CHF 2.20
3/8"	12	100	82819	5	CHF 2.30
3/8"	12	120	82821	5	CHF 2.70
3/8"	12	150	82824	5	CHF 3.10
3/8"	12	200	82829	5	CHF 4.50
1/2"	15	40	82843	5	CHF 1.70
1/2"	15	50	82844	5	CHF 1.90
1/2"	15	60	82845	5	CHF 2.30
1/2"	15	70	82846	5	CHF 2.40
1/2"	15	80	82847	5	CHF 2.60
1/2"	15	90	82848	5	CHF 2.80
1/2"	15	100	82849	5	CHF 3.00
1/2"	15	110	82850	5	CHF 3.10
1/2"	15	120	82851	5	CHF 3.50
1/2"	15	130	82852	5	CHF 3.50
1/2"	15	140	82853	5	CHF 3.60
1/2"	15	150	82854	5	CHF 4.00
1/2"	15	160	82855	5	CHF 4.10
1/2"	15	170	82856	5	CHF 4.30



**Langnippel Edelstahl 316**  
*Mamelon double longue acier inoxydable 316*  
*Bocciolo doppio lunghi acciaio inossidabile 316*

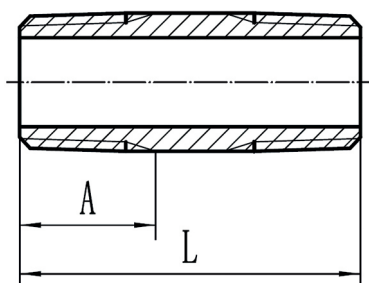

Zoll Pouce Pollice	A	L	Art.-Nr. No. Art.	Verp.-Einh. Unité Emb. Unità Imb.	CHF/ Stück Pièce Pezzo
1/2"	15	180	82857	5	CHF 4.50
1/2"	15	190	82858	5	CHF 4.70
1/2"	15	200	82859	5	CHF 5.70
1/2"	15	250	82860	5	CHF 6.30
1/2"	15	300	82861	5	CHF 7.30
3/4"	17	40	82873	5	CHF 2.10
3/4"	17	50	82874	5	CHF 2.40
3/4"	17	60	82875	5	CHF 2.80
3/4"	17	70	82876	5	CHF 2.90
3/4"	17	80	82877	5	CHF 3.20
3/4"	17	90	82878	5	CHF 3.50
3/4"	17	100	82879	5	CHF 3.80
3/4"	17	110	82880	5	CHF 3.80
3/4"	17	120	82881	5	CHF 4.40
3/4"	17	130	82882	5	CHF 4.30
3/4"	17	140	82883	5	CHF 4.60
3/4"	17	150	82884	5	CHF 5.00
3/4"	17	160	82885	5	CHF 5.10
3/4"	17	170	82886	5	CHF 5.10
3/4"	17	180	82887	5	CHF 5.80
3/4"	17	190	82888	5	CHF 5.90
3/4"	17	200	82889	5	CHF 6.60
3/4"	17	250	82890	5	CHF 7.60
3/4"	17	300	82891	5	CHF 8.90
1"	19	40	82903	5	CHF 2.70
1"	19	50	82904	5	CHF 3.10
1"	19	60	82905	5	CHF 3.70
1"	19	70	82906	5	CHF 3.90
1"	19	80	82907	5	CHF 4.20
1"	19	90	82908	5	CHF 4.20
1"	19	100	82909	5	CHF 5.00
1"	19	110	82910	5	CHF 5.00
1"	19	120	82911	2	CHF 5.80
1"	19	130	82912	2	CHF 5.80
1"	19	140	82913	2	CHF 6.10

**Langnippel Edelstahl 316**  
*Mamelon double longue acier inoxydable 316*  
*Bocciolo doppio lunghi acciaio inossidabile 316*

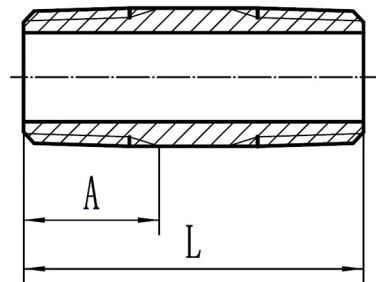

Zoll Pouce Pollice	A	L	Art.-Nr. No. Art.	Verp.-Einh. Unité Emb. Unità Imb.	CHF/ Stück Pièce Pezzo
1"	19	150	82914	2	CHF 6.80
1"	19	160	82915	2	CHF 6.90
1"	19	170	82916	2	CHF 7.20
1"	19	180	82917	2	CHF 7.90
1"	19	190	82918	2	CHF 8.60
1"	19	200	82919	2	CHF 9.40
1"	19	250	82920	2	CHF 10.80
1"	19	300	82921	2	CHF 12.70
1 1/4"	22	50	82934	5	CHF 4.00
1 1/4"	22	60	82935	5	CHF 4.50
1 1/4"	22	70	82936	5	CHF 5.00
1 1/4"	22	80	82937	5	CHF 6.30
1 1/4"	22	90	82938	5	CHF 6.10
1 1/4"	22	100	82939	2	CHF 6.60
1 1/4"	22	110	82940	2	CHF 6.80
1 1/4"	22	120	82941	2	CHF 7.80
1 1/4"	22	140	82943	2	CHF 8.20
1 1/4"	22	150	82944	2	CHF 9.40
1 1/4"	22	160	82945	2	CHF 9.30
1 1/4"	22	180	82947	2	CHF 10.20
1 1/4"	22	200	82949	2	CHF 12.20
1 1/2"	22	50	82964	5	CHF 4.60
1 1/2"	22	60	82965	5	CHF 5.20
1 1/2"	22	70	82966	5	CHF 5.90
1 1/2"	22	80	82967	5	CHF 7.60
1 1/2"	22	90	82968	2	CHF 7.10
1 1/2"	22	100	82969	2	CHF 7.80
1 1/2"	22	120	82971	2	CHF 9.10
1 1/2"	22	140	82973	2	CHF 9.60
1 1/2"	22	150	82974	2	CHF 11.00
1 1/2"	22	160	82975	2	CHF 11.00
1 1/2"	22	180	82977	2	CHF 12.00
1 1/2"	22	200	82979	2	CHF 14.40
2"	26	60	82994	5	CHF 7.00
2"	26	70	82995	5	CHF 7.80

**Langnippel Edelstahl 316**  
*Mamelon double longue acier inoxydable 316*  
*Bocciolo doppio lunghi acciaio inossidabile 316*

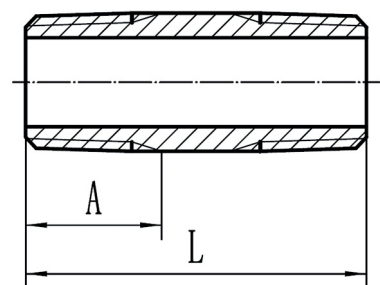

Zoll Pouce Pollice	A	L	Art.-Nr. No. Art.	Verp.-Einh. Unité Emb. Unità Imb.	CHF/ Stück Pièce Pezzo
2"	26	80	82996	5	CHF 8.70
2"	26	90	82997	2	CHF 9.60
2"	26	100	82998	2	CHF 11.40
2"	26	120	82999	2	CHF 12.20
2"	26	150	83001	2	CHF 14.90
2"	26	200	83004	2	CHF 19.70
2 1/2"	32	100	83019	2	CHF 18.00
2 1/2"	32	120	83020	2	CHF 19.80
2 1/2"	32	140	83021	2	CHF 23.10
2 1/2"	32	160	83022	2	CHF 25.20
2 1/2"	32	180	83023	2	CHF 28.20
2 1/2"	32	200	83024	2	CHF 30.90
3"	34	100	83036	2	CHF 20.30
3"	34	120	83037	2	CHF 25.80
3"	34	160	83039	2	CHF 30.70
3"	34	200	83041	2	CHF 40.90
4"	40	120	83058	2	CHF 43.20

Schweissnippel Edelstahl 316  
 Mamelon de soudage acier inoxydable 316  
 Boccioło saldatura acciaio inossidabile 316

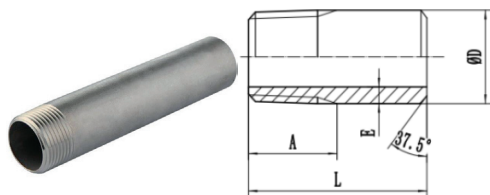

Zoll Pouce Pollice	A	L	E	D	Art.-Nr. No. Art.	Verp.-Einh. Unité Emb. Unità Imb.	CHF/ Stück Pièce Pezzo
1/8"	8	30	+0.2 1.73	10.3 ± 0.2	<b>82580</b>	5	<b>1.10</b>
1/4"	11	30	+0.2 2-0	13.72 ± 0.2	<b>82581</b>	5	<b>1.10</b>
3/8"	12	30	+0.2 2.1-0	17.15 ± 0.2	<b>82582</b>	5	<b>1.20</b>
1/2"	15	35	+0.2 2.5-0	21.34 ± 0.2	<b>82583</b>	5	<b>1.70</b>
3/4"	17	40	+0.2 2.5-0	26.67 ± 0.2	<b>82584</b>	5	<b>2.10</b>
1"	19	40	+0.2 3-0	33.4 ± 0.2	<b>82585</b>	5	<b>2.80</b>
1 1/4"	22	50	+0.2 3.2-0	42.16 ± 0.2	<b>82586</b>	5	<b>4.60</b>
1 1/2"	22	50	+0.3 3.3-0	48.26 ± 0.2	<b>82587</b>	5	<b>5.40</b>
2"	26	50	+0.3 3.5-0	+0.2 60.33-0.4	<b>82588</b>	2	<b>6.90</b>
2 1/2"	32	60	+0.5 4.6-0	+0.2 76.3-0.4	<b>82589</b>	2	<b>11.80</b>
3"	34	70	+0.5 5-0	+0.2 88.9-0.4	<b>82590</b>	1	<b>16.40</b>
4"	40	80	+0.5 5.5-0	+0.2 114.3-0.4	<b>82591</b>	1	<b>25.10</b>

**Winkel 90° IG/IG Edelstahl 316**  
**Coude 90° f/f acier inoxydable 316**  
**Gomito 90° f/f acciaio inossidabile 316**

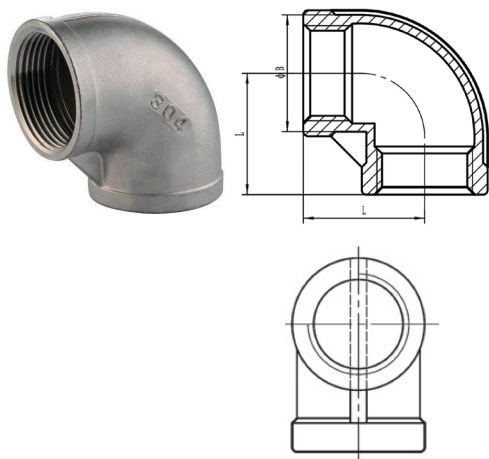

Zoll Pouce Pollice	L	A	t	Art.-Nr. No. Art.	Verp.-Einh. Unité Emb. Unità Imb.	CHF/ Stück Pièce Pezzo
1/8"	17	14.5	1.5	82130	5	2.00
1/4"	19	18	1.5	82131	5	2.10
3/8"	23	21.5	1.5	82132	5	2.20
1/2"	27	26	1.8	82133	5	2.70
3/4"	32	31.5	1.8	82134	5	4.00
1"	38	39	2	82135	2	6.40
1 1/4"	45	48	2.4	82136	2	11.00
1 1/2"	48	55	2.5	82137	2	13.60
2"	57	67.5	2.8	82138	1	21.70
2 1/2"	69	84	3.3	82139	1	36.00
3"	78	98.5	3.8	82140	1	58.20
4"	96	124.5	4.3	82141	1	93.40

**Winkel 90° IG/AG Edelstahl 316**  
**Coude 90° f/m acier inoxydable 316**  
**Gomito 90° f/m acciaio inossidabile 316**

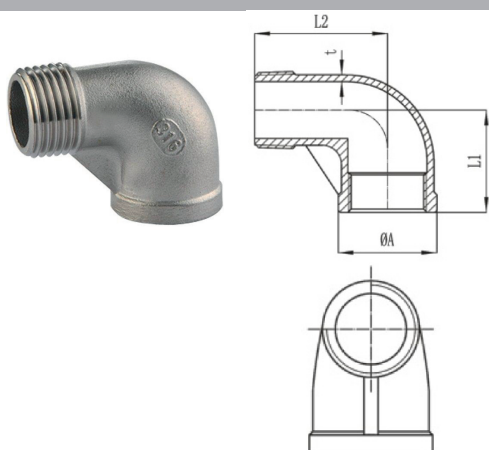

Zoll Pouce Pollice	L1	L2	A	T	I	Art.-Nr. No. Art.	Verp.-Einh. Unité Emb. Unità Imb.	CHF/ Stück Pièce Pezzo
1/8"	17	26	13	1.5	5.5	82150	5	2.10
1/4"	19	27	16.5	1.5	8	82151	5	2.20
3/8"	23	29	19.7	1.5	11.5	82152	5	2.60
1/2"	27	35	24.5	1.8	15	82153	5	2.80
3/4"	32	40	30	1.8	20.5	82154	5	3.80
1"	38	46	37.5	2	26	82155	2	6.80
1 1/4"	45	54	46.5	2.4	34.5	82156	2	10.90
1 1/2"	48	57	53	2.5	40	82157	2	13.20
2"	57	70	65.5	2.8	51	82158	1	22.80
2 1/2"	69	83	82	3.3	65.5	82159	1	43.30
3"	78	94	95.5	3.7	77.5	82160	1	59.30
4"	96	115	121.5	4.2	101.5	82161	1	93.60

**Winkel 90° reduziert IG/IG Edelstahl 316**  
**Coude 90° réduit f/f acier inoxydable 316**  
**Gomito 90° ridotto f/f acciaio inossidabile 316**

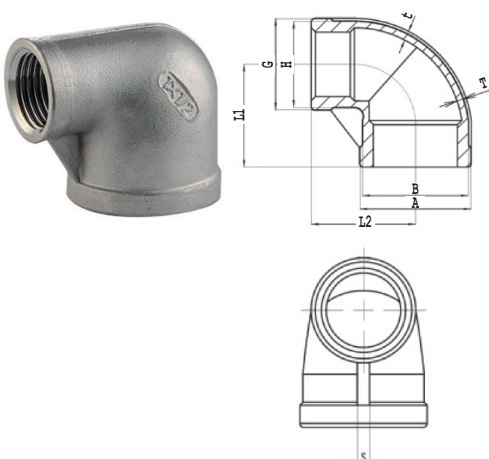

Zoll Pouce Pollice	L1	L2	G	H	t	A	B	T	Art.-Nr. No. Art.	Verp.-Einh. Unité Emb. Unità Imb.	CHF/ Stück Pièce Pezzo
1/4" x 1/8"	18	18	14	13	1.6	18	16.5	1.6	82540	5	1.60
3/8" x 1/4"	20	22	18	16.5	1.6	21.5	20	1.6	82541	5	1.90
1/2" x 3/8"	26	25	21.5	20	1.6	26	24.5	1.8	82542	5	2.50
3/4" x 3/8"	28	28	21.5	20	1.6	31.5	30	1.8	82543	5	3.00
3/4" x 1/2"	29	30	26	24.5	1.8	31.5	30	1.8	82544	5	3.20
1" x 1/2"	32	33	26	24.5	1.8	39	37.5	2	82545	5	4.60
1" x 3/4"	34	35	31.5	30	1.8	39	37.5	2	82546	5	5.30
1 1/4" x 3/4"	38	40	31.5	30	1.8	48	46.5	2.4	82547	2	7.40
1 1/4" x 1"	40	42	39	37.5	2	48	46.5	2.4	82548	2	14.20
1 1/4" x 1/2"	34,5	36	28,5	26,5	1,8	50	47,5	2,4	82549	2	6,30
1 1/2" x 1"	41	45	39	37,5	2	55	53	2,5	82550	2	10,90
1 1/2" x 1 1/4"	45	48	48	46,5	2,4	55	53	2,5	82551	2	11,60
2" x 1 1/2"	52	55	55	53	2,5	67,5	65,5	2,8	82552	1	24,20

**Winkel 45° IG/IG Edelstahl 316**  
*Coude 45° f/f acier inoxydable 316*  
*Gomito 45° f/f acciaio inossidabile 316*

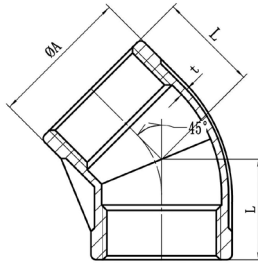

Zoll Pouce Pollice	L	A	t	Art.-Nr. No. Art.	Verp.-Einh. Unité Emb. Unità Imb.	CHF/ Stück Pièce Pezzo
1/8"	16	14.5	2.3	82170	5	1.80
1/4"	17	18	2.55	82171	5	1.80
3/8"	19	21.5	2.55	82172	5	1.90
1/2"	21	26	1.8	82173	5	2.20
3/4"	25	31.5	1.8	82174	5	3.20
1"	29	39	2	82175	2	5.80
1 1/4"	33	48	2.4	82176	2	8.10
1 1/2"	37	55	2.5	82177	2	11.80
2"	42	67.5	2.8	82178	1	18.00
2 1/2"	49	84	3.3	82179	1	32.40
3"	54	98.5	3.8	82180	1	47.70
4"	64	124.5	4.3	82181	1	79.20

**Winkel 45° IG/AG Edelstahl 316**  
*Coude 45° f/m acier inoxydable 316*  
*Gomito 45° f/m acciaio inossidabile 316*

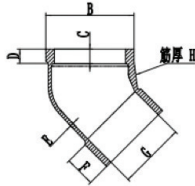

Zoll Pouce Pollice	B	C	D	E	F	G	H	Art.-Nr. No. Art.	Verp.-Einh. Unité Emb. Unità Imb.	CHF/ Stück Pièce Pezzo
1/2"	25.2	9	5	1.3	12.5	16	3,2	82182	5	2.40
3/4"	31	11.5	6	1.5	12	22	3.8	82183	5	3.20
1"	38.5	13.5	8	1.8	14	27	4	82184	5	5.80
1 1/4"	48	12.5	9	1.8	18.5	36	4.5	82185	2	7.90
1 1/2"	55	16	11	2.2	19	40.5	4.5	82186	2	11.50
2"	66.5	16	10	2.5	23	50.5	5	82187	1	18.00

**T-Stück Edelstahl 316**  
*Té acier inoxydable 316*  
*Tee acciaio inossidabile 316*

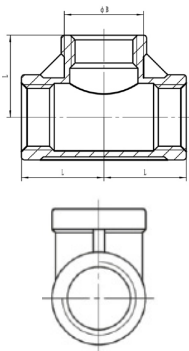

Zoll Pouce Pollice	L	A	T	Art.-Nr. No. Art.	Verp.-Einh. Unité Emb. Unità Imb.	CHF/ Stück Pièce Pezzo
1/8"	17	13	2.4	82011	5	1.80
1/4"	19	16.5	2.7	82012	5	2.00
3/8"	23	19.7	2.9	82013	5	2.90
1/2"	27	24.5	1.8	82014	5	3.70
3/4"	32	30	1.8	82015	5	5.30
1"	38	37.5	2	82016	2	8.50
1 1/4"	45	46.5	2.4	82017	2	13.40
1 1/2"	48	53	2.5	82018	2	17.80
2"	57	65.5	2.8	82019	1	27.20
2 1/2"	69	82	3.3	82020	1	49.00
3"	78	95.5	3.8	82021	1	76.90
4"	96	121.5	4.3	82022	1	133.40

**T-Stück reduziert Edelstahl 316**  
*Té réduit acier inoxydable 316*  
*Tee ridotto acciaio inossidabile 316*

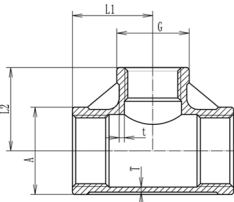

Zoll Pouce Pollice	L1	L2	G	t	A	T	Art.-Nr. No. Art.	Verp.-Einh. Unité Emb. Unità Imb.	CHF/ Stück Pièce Pezzo
1/4" x 1/8"	18	18	14	1.6	18	1.6	82480	5	2.00
3/8" x 1/4"	20	22	18	1.6	21.5	1.6	82482	5	3.10
1/2" x 1/4"	24	24	18	1.6	26	1.8	82483	5	3.20
1/2" x 3/8"	26	25	21.5	1.6	26	1.8	82484	5	3.50
3/4" x 3/8"	28	28	21.5	1.6	31.5	1.8	82485	5	4.40
3/4" x 1/2"	29	30	26	1.8	31.5	1.8	82486	5	5.70
1" x 1/2"	32	33	26	1.8	39	2	82487	2	6.80
1" x 3/4"	34	35	31.5	1.8	39	2	82488	2	7.50
1 1/4" x 3/4"	38	40	31.5	1.8	48	2.4	82490	2	10.30
1 1/4" x 1"	40	42	39	2	48	2.4	82491	2	11.70
1 1/2" x 1"	41	45	39	2	55	2.5	82494	2	14.60
1 1/2" x 1 1/4"	45	48	48	2.4	55	2.5	82495	1	18.10
2" x 1 1/4"	48	54	48	2.4	67.5	2.8	82498	1	22.40
2" x 1 1/2"	52	55	55	2.5	67.5	2.8	82499	1	25.20

**Cross Edelstahl 316**  
*Croix acier inoxydable 316*  
*Crocce acciaio inossidabile 316*

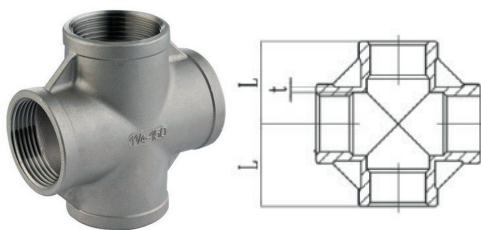

Zoll Pouce Pollice	L	T	Art.-Nr. No. Art.	Verp.-Einh. Unité Emb. Unità lmb.	CHF/ Stück Pièce Pezzo
1/8"	17	2.5	82030	5	1.80
1/4"	19	3	82031	5	2.30
3/8"	23	3	82032	5	3.60
1/2"	27	1.8	82033	5	4.40
3/4"	32	1.8	82034	5	8.70
1"	38	2	82035	2	10.70
1 1/4"	45	2.4	82036	2	16.60
1 1/2"	48	2.5	82037	1	23.90
2"	57	2.8	82038	1	34.90
2 1/2"	69	3.3	82039	1	63.10
3"	78	3.8	82040	1	91.40
4"	96	4.3	82041	1	179.20

**Rohrverschraubung AG/IG konisch dichtend**  
**Edelstahl 316**  
*Union conique m/f acier inoxydable 316*  
*Bocchettone conico m/f acciaio inossidabile 316*

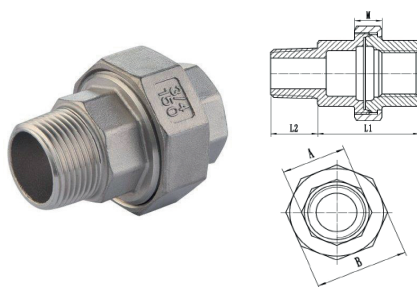

Zoll Pouce Pollice		A	B	L1	L2	M	Art.-Nr. No. Art.	Verp.-Einh. Unité Emb. Unità lmb.	CHF/ Stück Pièce Pezzo
1/8"	6	13	26	30	8	13	82310	5	4.00
1/4"	8	16.5	29	33.5	10.5	13.5	82311	5	5.50
3/8"	8	20	34	36.5	11	15	82312	5	7.10
1/2"	8	24.5	37	39.5	14.5	16	82313	5	8.90
3/4"	8	30	44	42.5	15.5	17	82314	2	13.80
1"	8	37	52.5	50	18	20	82315	2	18.60
1 1/4"	8	46.5	63	54	20.5	22	82316	1	26.20
1 1/2"	8	53	70	58	20.5	24	82317	1	31.30
2"	8	65	84	65	25	27	82318	1	48.70
2 1/2"	10	82	101.5	75	27	29.5	82319	1	79.60
3"	10	95.5	118	83	30	31	82320	1	103.50
4"	10	121.5	148.5	110	36	34	82321	1	168.80

**Rohrverschraubung AG/IG flachdichtend**  
**Edelstahl 316**  
*Manchon union à joint plat f/m acier inoxydable 316*  
*Bocchettone a sede piana f/m acciaio inossidabile 316*

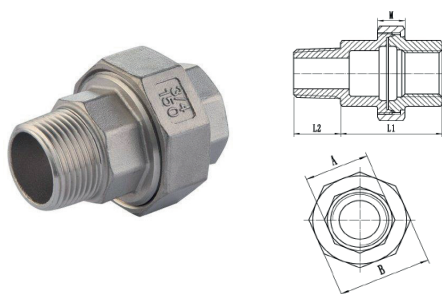

Zoll Pouce Pollice		A	B	L1	L2	M	Art.-Nr. No. Art.	Verp.-Einh. Unité Emb. Unità lmb.	CHF/ Stück Pièce Pezzo
1/4"	8	16.5	29	33.5	10.5	13.5	82331	5	5.70
3/8"	8	20	34	36.5	11	15	82332	5	7.30
1/2"	8	24.5	37	39.5	14.5	16	82333	2	9.90
3/4"	8	30	44	42.5	15.5	17	82334	2	14.00
1"	8	37	52.5	50	18	20	82335	1	19.00
1 1/4"	8	46.5	63	54	20.5	24	82336	1	27.00
1 1/2"	8	53	70	58	20.5	24	82337	1	33.00
2"	8	65	84	65	25	27	82338	1	49.00
2 1/2"	10	82	101.5	75	27	29.5	82339	1	79.90
3"	10	95.5	118	83	30	31	82340	1	105.00

**Rohrverschraubung AG/AG konisch dichtend**  
**Edelstahl 316**  
*Union conique m/m acier inoxydable 316*  
*Bocchettone conico m/m acciaio inossidabile 316*

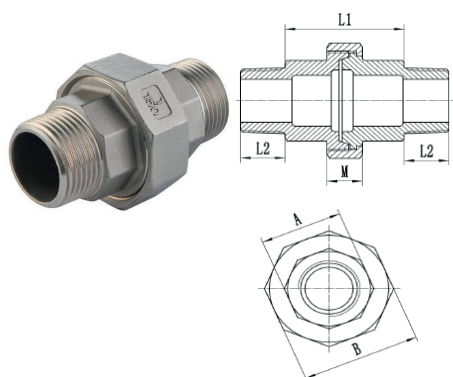

Zoll Pouce Pollice		A	B	L1	L2	M	Art.-Nr. No. Art.	Verp.-Einh. Unité Emb. Unità lmb.	CHF/ Stück Pièce Pezzo
1/8"	6	13	26	30	8	13	82350	5	4.80
1/4"	8	16.5	29	33.5	10.5	13.5	82351	5	6.70
3/8"	8	20	34	36.5	11	15	82352	2	8.80
1/2"	8	24.5	37	39.5	14.5	16	82353	2	11.00
3/4"	8	30	44	42.5	15.5	17	82354	1	16.90
1"	8	37	52.5	50	18	20	82355	1	23.00
1 1/4"	8	46.5	63	54	20.5	22	82356	1	32.30
1 1/2"	8	53	70	58	20.5	24	82357	1	38.60
2"	8	65	84	65	25	27	82358	1	59.90
2 1/2"	10	82	101.5	75	27	29.5	82359	1	98.00
3"	10	95.5	118	83	30	31	82360	1	123.80
4"	10	121.5	148.5	110	36	34	82361	1	207.80

Rohrverschraubung IG/IG konisch dichtend  
Edelstahl 316  
*Union conique f/f acier inoxydable 316*  
*Bocchettone conico f/f acciaio inossidabile 316*

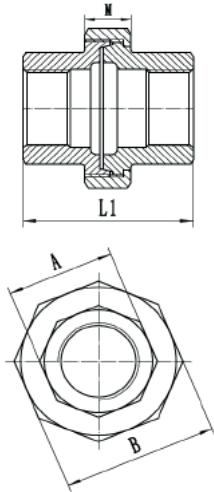

Zoll Pouce Pollice		A	B	L1	M	Art.-Nr. No. Art.	Verp.-Einh. Unité Emb. Unità lmb.	CHF/ Stück Pièce Pezzo
1/8"	6	13	26	30	13	82250	5	3.00
1/4"	8	16.5	29	33.5	13.5	82251	5	4.20
3/8"	8	20	34	36.5	15	82252	5	5.60
1/2"	8	24.5	37	39.5	16	82253	5	6.60
3/4"	8	30	44	42.5	17	82254	2	9.70
1"	8	37	52.5	50	20	82255	2	14.90
1 1/4"	8	46.5	63	65	24	82256	1	21.40
1 1/2"	8	53	70	58	24	82257	1	28.80
2"	8	65	84	65	27	82258	1	41.50
2 1/2"	10	82	101.5	75	29.5	82259	1	60.40
3"	10	95.5	118	83	31	82260	1	86.10
4"	10	121.5	148.5	110	34	82261	1	147.40

Rohrverschraubung IG/IG flachdichtend PTFE,  
Edelstahl 316  
*Manchon union à joint plat f/f acier inoxydable 316*  
*Bocchettone a sede piana f/f acciaio inossidabile 316*

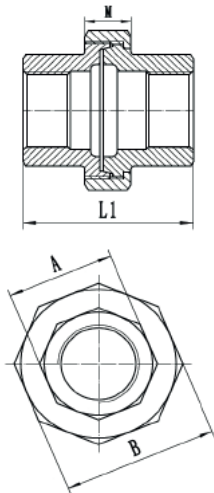

Zoll Pouce Pollice		A	B	L1	M	Art.-Nr. No. Art.	Verp.-Einh. Unité Emb. Unità lmb.	CHF/ Stück Pièce Pezzo
1/8"	6	16.5	29	33.5	13.5	82291	5	5.20
1/4"	8	20	34	36.5	15	82292	5	6.60
3/8"	8	24.5	37	39.5	16	82293	5	7.90
1/2"	8	30	44	42.5	17	82294	2	10.90
3/4"	8	37	52.5	50	20	82295	2	15.90
1"	8	46.5	63	54	24	82296	1	22.90
1 1/4"	8	53	70	58	24	82297	1	29.90
1 1/2"	8	65	84	65	27	82298	1	42.90
2"	8	82	101.5	75	29.5	82299	1	64.00
2 1/2"	10	95.5	118	83	31	82300	1	89.00

Anschweisverschraubung I/I Edelstahl 316  
*Union soudage f/f acier inoxydable 316*  
*Bocchettone f/f saldatura inossidabile 316*

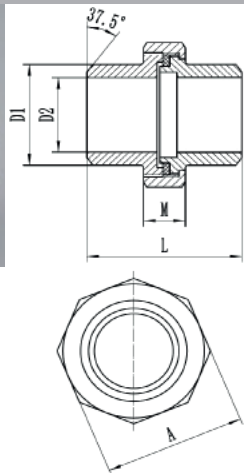

Zoll Pouce Pollice		L	M	A	D1	D2	Art.-Nr. No. Art.	Verp.-Einh. Unité Emb. Unità lmb.	CHF/ Stück Pièce Pezzo
1/4"	8	33.5	13.5	29	13.7	9.2	82271	5	4.20
3/8"	8	36.5	15	34	17.2	12.5	82272	5	5.60
1/2"	8	39.5	16	37	21.3	15.8	82273	5	6.60
3/4"	8	42.5	17	44	26.7	20.9	82274	2	9.70
1"	8	50	20	52.5	33.4	26.6	82275	2	14.90
1 1/4"	8	54	22	63	42.2	35	82276	1	21.40
1 1/2"	8	58	24	70	48.3	40.9	82277	1	28.80
2"	8	65	27	84	60.3	52.5	82278	1	41.50
2 1/2"	10	75	29.5	101.5	76.1	65.8	82279	1	60.40
3"	10	83	31	118	88.9	77.9	82280	1	86.10
4"	10	110	34	148.5	114.3	102.3	82281	1	147.40



**Anschweissverschraubung A/A Edelstahl 316**  
*Union soudage m/m acier inoxydable 316*  
*Bocchettone m/m saldatura inossidabile 316*

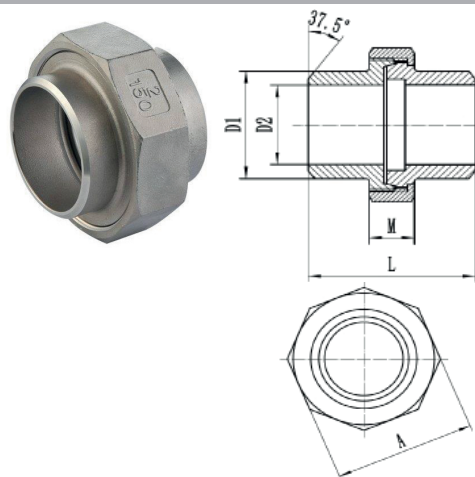

Zoll Pouce Pollice		L	M	A	D1	D2	Art.-Nr. No. Art.	Verp.-Einh. Unité Emb. Unità Imb.	CHF/ Stück Pièce Pezzo
1/4"	6	33.5	13.5	29	13.7	9.2	82371	5	4.20
3/8"	8	36.5	15	34	17.2	12.5	82372	5	5.50
1/2"	8	39.5	16	37	21.3	15.8	82373	5	6.90
3/4"	8	42.5	17	44	26.7	20.9	82374	2	10.60
1"	8	50	20	52.5	33.4	26.6	82375	2	14.40
1 1/4"	8	54	22	63	42.5	35	82376	1	20.20
1 1/2"	8	58	24	70	48.3	40.9	82377	1	24.10
2"	8	65	27	84	60.3	52.5	82378	1	37.50
2 1/2"	8	75	29.5	101.5	76.1	65.8	82379	1	61.30
3"	10	83	31	118	88.9	77.9	82380	1	83.20
4"	10	110	34	148.5	114.3	102.3	82381	1	129.90

**Gegenmutter Edelstahl 316**  
*Contre-écrou acier inoxydable 316*  
*controdado acciaio inossidabile 316*

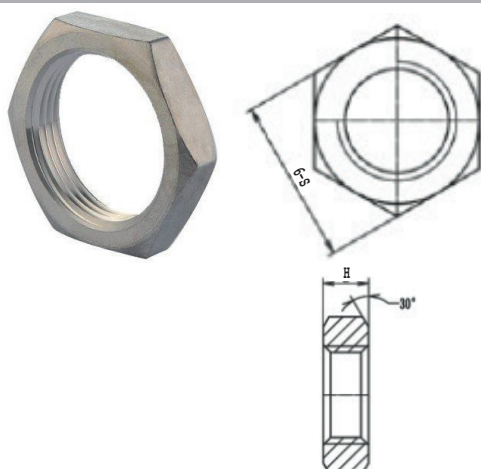

Zoll Pouce Pollice	H	S	Art.-Nr. No. Art.	Verp.-Einh. Unité Emb. Unità Imb.	CHF/ Stück Pièce Pezzo
1/8"	6	15	82050	5	1.90
1/4"	6	18	82051	5	2.00
3/8"	6	24	82052	5	2.20
1/2"	7	30	82053	5	3.00
3/4"	7	34	82054	5	3.00
1"	9	42.5	82055	5	3.40
1 1/4"	11	52	82056	5	3.50
1 1/2"	11	58	82057	5	4.10
2"	13	72	82058	2	7.00

**Legende für Gewinde - Légende pour le fil - Legenda per filo**

1/8" - 1/2"	6	Hexagon 6 Kt
3/4" - 2"	8	Octagon 8 Kt
2 1/2" - 4"	10	Decagon 10 Kt

**Stopfen Hexagon Edelstahl 316**  
*Bouchon Hexagon acier inoxydable 316*  
*Tappo Hexagon acciaio inossidabile 316*

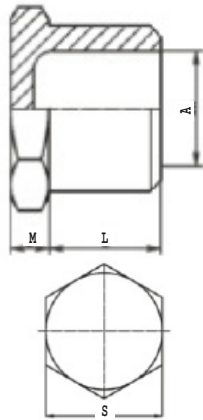

Zoll Pouce Pollice	A	S	M	L	Art.-Nr. No. Art.	Verp.-Einh. Unité Emb. Unità Imb.	CHF/ Stück Pièce Pezzo
1/8"	5.5	12.5	4	8	82210	5	1.70
1/4"	8	15	4	10.5	82211	5	2.00
3/8"	11.5	18.5	5	11	82212	5	2.10
1/2"	15	22.5	5	14.5	82213	5	2.30
3/4"	20.5	28	5.5	15.5	82214	5	2.60
1"	26	35	6	18	82215	5	3.00
1 1/4"	34.5	44	6.5	20.5	82216	5	4.70
1 1/2"	40	50.5	6.5	20.5	82217	5	5.90
2"	51	62.5	7	25	82218	2	10.00
2 1/2"	65.5	78.5	7	27	82219	1	16.20
3"	77.5	92	7.5	30	82220	1	24.10
4"	101.5	118	8	36	82221	1	43.00

**Stopfen 4-kant ohne Rand Edelstahl 316**  
*Bouchon carré acier inoxydable 316*  
*Tappo quadrato acciaio inossidabile 316*

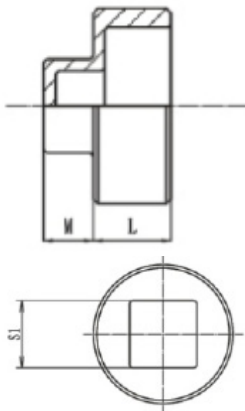

Zoll Pouce Pollice	L	M	S1	Art.-Nr. No. Art.	Verp.-Einh. Unité Emb. Unità Imb.	CHF/ Stück Pièce Pezzo
1/8"	5	5	7	82230	5	1.70
1/4"	6	5	7	82231	5	1.80
3/8"	9	6	10	82232	5	2.00
1/2"	11.5	7	11	82233	5	2.20
3/4"	13	8	15	82234	5	2.40
1"	14.5	11	18	82235	5	3.40
1 1/4"	17	11	20.5	82236	5	3.60
1 1/2"	17	12	22	82237	5	4.40
2"	21.5	13	28	82238	2	8.00
2 1/2"	23.5	15	32	82239	1	12.90
3"	26.5	15	36	82240	1	18.90
4"	32.5	19	42	82241	1	37.80

**Kappe Edelstahl 316**  
*Bonnet double acier inoxydable 316*  
*Tappo doppio acciaio inossidabile 316*

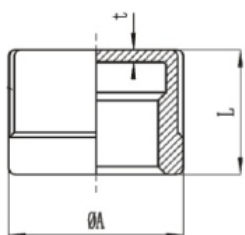

Zoll Pouce Pollice	A	T	L	Art.-Nr. No. Art.	Verp.-Einh. Unité Emb. Unità Imb.	CHF/ Stück Pièce Pezzo
1/8"	14	1.6	10.5	82090	5	1.60
1/4"	18	1.6	14	82091	5	1.80
3/8"	21.5	1.6	14.5	82092	5	2.00
1/2"	26	1.8	18.5	82093	5	2.10
3/4"	31.5	1.8	19.5	82094	5	2.40
1"	39	2	22.5	82095	5	2.80
1 1/4"	48	2.4	25.5	82096	2	5.80
1 1/2"	55	2.5	25.5	82097	2	7.90
2"	67.5	2.8	30	82098	2	11.50
2 1/2"	84	3.3	35	82099	1	20.00
3"	98.5	3.8	38.5	82100	1	30.20
4"	124.5	4.3	45	82101	1	47.70

**Kappe Hexagon Edelstahl 316**  
*Bonnet Hexagon acier inoxydable 316*  
*Tappo Hexagon acciaio inossidabile 316*

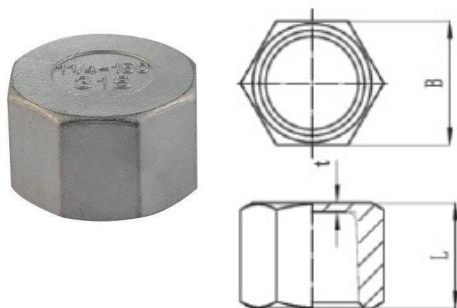

Zoll Pouce Pollice	B	T	L	Art.-Nr. No. Art.	Verp.-Einh. Unité Emb. Unità lmb.	CHF/ Stück Pièce Pezzo
1/8"	13	1.3	12.5	82190	5	1.70
1/4"	16.5	1.5	16	82191	5	1.80
3/8"	19.8	1.5	16.5	82192	5	1.80
1/2"	24.5	2.2	21	82193	5	2.00
3/4"	30	2.2	22.2	82194	5	3.20
1"	37	2.4	26	82195	2	3.50
1 1/4"	46.5	2.8	29	82196	2	4.40
1 1/2"	53	2.8	29	82197	2	7.40
2"	65	3.2	33.5	82198	1	11.40
2 1/2"	82	3.5	38.5	82199	1	22.00
3"	95.5	4	42	82200	1	30.70
4"	120	4	48	82201	1	54.00

**Schlauchnippel Edelstahl 316**  
*Raccord de tuyau acier inoxydable 316*  
*Capezzolo tubo acciaio inossidabile 316*

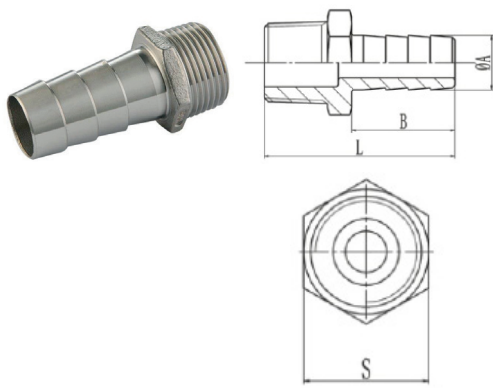

Zoll Pouce Pollice	L	A	B	S	Art.-Nr. No. Art.	Verp.-Einh. Unité Emb. Unità lmb.	CHF/ Stück Pièce Pezzo
1/8"	41	8	24	12.8	82110	5	1.80
1/4"	42.5	9	28	15	82111	5	2.00
3/8"	49	11.5	33	18	82112	5	2.40
1/2"	57.5	15	38	22	82113	5	2.80
3/4"	66	20	45	28	82114	5	3.80
1"	76	27	52	35	82115	2	6.50
1 1/4"	79	33	52	44	82116	2	10.00
1 1/2"	83	39.5	56	50	82117	2	11.70
2"	92	52	60	61.5	82118	1	19.30
2 1/2"	99	67	65	78	82119	1	30.80
3"	107.5	80	70	90	82120	1	46.80
4"	146	103	91.5	117	82121	1	73.20

**Gewindeflansch PN 16, gebohrt,**  
*DIN 2566, Edeldstahl 316*  
*Bride fileté PN 16, percée,*  
*DIN 2566, inox 316*  
*Flangia filettata PN 16, forata,*  
*DIN 2566, inox 316*



Zoll Pouce Pollice	Anz. Bohr.	DN	d1	D	b	k	h	d3	d4	f	Art.-Nr. No. Art.	CHF/ Stück Pièce Pezzo
1/2"	4	15	21,3	95	14	65	20	35	45	2	82650	20.90
3/4"	4	20	26,9	105	16	75	24	45	58	2	82651	31.00
1"	4	25	33,7	115	16	85	24	52	68	2	82652	37.50
1 1/4"	4	32	42,4	140	16	100	26	60	78	2	82653	49.00
1 1/2"	4	40	48,3	150	16	110	26	70	88	2	82654	55.00
2"	4	50	60,3	165	18	125	28	85	102	2	82655	75.00
2 1/2"	4	65	76,1	185	18	145	32	105	122	2	82656	96.00
3"	8	80	88,9	200	20	160	34	118	138	2	82657	120.00
4"	8	100	114,3	220	20	180	38	140	158	2	82658	135.00

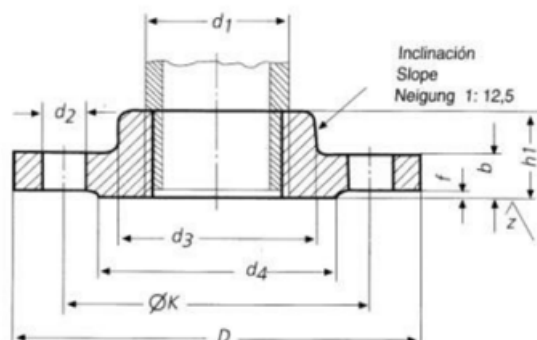

grösste Typenvielfalt zum attraktiven Preis

*Une grande gamme à un prix attractif*

*Programma ampio e prezzi interessanti*



Solaranlagen  
*Centrales solaires*  
*Impianti solari*



Wasserversorgung  
*Approvisionnement en eau*  
*Approvvigionamento idrico*



Kühlanlagen  
*Systèmes de refroidissement*  
*Sistemi di raffreddamento*



Heizanlagen  
*Systèmes de chauffage*  
*Sistemi di riscaldamento*



zertifiziert\*  
*certifié\**  
*certificato\**

**Hess Metalle AG**

Hagackerstrasse 10 | CH-8953 Dietikon

Telefon: 044 740 25 25

info@hessmetalle.ch | www.hessmetalle.ch